



Astra™ Machina™ SL1620 Developer Kit User Guide

PN: 511-001407-01 Rev E

Downloaded by Anonymous () on 12 Jan 2026 18:12:47 UTC

Table of Contents

1.	Introduction.....	5
1.1.	Scope.....	5
1.2.	Definition of Board Components.....	6
1.3.	Astra Machina System Overview.....	7
1.3.1.	Features.....	8
1.3.2.	SL1620 system block diagram.....	9
1.3.3.	Top view of SL1620 Astra Machina Developer Kit.....	10
1.3.4.	System connectors.....	11
2.	Astra Machina Board Control/Status & System I/O.....	12
2.1.	Bootup.....	12
2.2.	LEDs.....	13
2.2.1.	LED locations.....	13
2.2.2.	LED definitions.....	13
2.3.	SoC Pinstrap and Bootup Settings.....	14
2.4.	Hardware Manual Button Settings.....	16
2.5.	Hardware Jumper Settings.....	17
2.6.	SL1620 Developer Kit Connectors.....	18
2.6.1.	Location of connector on the top side of the core module.....	18
2.6.2.	Locations of connectors on the bottom side of the core module.....	18
2.6.3.	Core module connector definitions.....	19
2.6.4.	Locations of connectors on the top side of the I/O board.....	19
2.6.5.	Location of connector on the bottom side of the I/O board.....	20
2.6.6.	I/O board connector definitions.....	21
3.	Daughter Cards.....	22
3.1.	Debug Board.....	22
3.2.	M.2 Card.....	22
3.3.	260-Pins SODIMM definition.....	23
3.4.	40-Pins Header.....	27
3.5.	Pin-demuxing for Standard Interface Configuration.....	28
3.6.	Pin-demuxing for GPIO/GPO Configuration.....	32
3.7.	GPIO Expanders Over I2C.....	36
3.8.	I2C Bus.....	38
4.	Bringing Up the SL1620 Astra Machina System.....	39
4.1.	Connecting External Components and Performing Hardware Testing.....	39
5.	Regulatory Compliance Certification.....	41
6.	References.....	42
7.	Revision History.....	43

List of Figures

Figure 1. SL1620 core module (Dimensions: WxH = 69.6 x 47.38mm).....	7
Figure 2. I/O board (Dimensions: WxH = 3937 x 3110mm).....	7
Figure 3. SL1620 system block diagram.....	9
Figure 4. Top view of SL1620 developer kit	10
Figure 5. Front view.....	11
Figure 6. Rear view.....	11
Figure 7. LED locations on I/O board.....	13
Figure 8. Locations of manual buttons on I/O board	16
Figure 9. Locations of jumpers on I/O board.....	17
Figure 10. Location of connector on the top side of the core module.....	18
Figure 11. Locations of connectors on the bottom side of the core module.....	18
Figure 12. Locations of connectors on the top side of the I/O board	19
Figure 13. Location of connector on the bottom side of the I/O board.....	20
Figure 14. Debug board connectivity for UART and JTAG.....	22
Figure 15. 40-pins header definition.....	27
Figure 16. Short and voltage check points.....	39

Downloaded by Anonymous () on 12 Jan 2026 18:12:27 UTC

List of Tables

Table 1. LED definitions on I/O board	13
Table 2. SoC pinstrap and bootup settings on core module.....	14
Table 3. Bootup settings on I/O board.....	15
Table 4. Hardware manual button settings definitions on I/O board.....	16
Table 5. Hardware jumper settings definitions on I/O board.....	17
Table 6. Core module connector definitions.....	19
Table 7. I/O board connector definitions	21
Table 8. 260-pins SODIMM definition.....	23
Table 9. SoC pin-demuxing usage.....	28
Table 10. SoC GPIO/GPO usage	32
Table 11. GPIO expanders usage.....	36
Table 12. I2C bus descriptions	38
Table 13. Short and voltage check points using any test point for ground	40

Downloaded by Anonymous () on 12 Jan 2026 18:12:27 UTC

1. Introduction

The Astra™ Machina™ Foundation Series of evaluation-ready kits enable easy and rapid prototyping for the Synaptics SL-Series of multi-modal embedded processors. A modular design incorporates swappable core compute modules, a common I/O board, and daughter cards for connectivity, debug, and flexible I/O options.

The Synaptics Astra SL-Series is a family of highly integrated AI-native Linux® and Android™ SoCs optimized for multi-modal consumer, enterprise, and industrial IoT workloads with hardware accelerators for edge inferencing, security, graphics, vision, and audio. The SL1620 is designed and optimized for embedded applications that require powerful processing, advanced AI capability, and 3D graphics. This chip comes with Linux® OS, superior audio algorithms, a variety of peripherals, dual displays, companion Synaptics SoC for connectivity and audio front end.

1.1. Scope

This user guide describes the hardware configuration and functional details for the Astra Machina SL1620 core module, I/O board, and supported daughter cards, in addition to the bring-up sequence for the developer kit.

Downloaded by Anonymous () on 12-Jan-2026 18:12:21 UTC

1.2. Definition of Board Components

- **Astra Machina:** Combined system with core module, I/O board, and supported daughter cards.
- **Core module:** Processor subsystem module with key components including SL1620, eMMC, and DDR4.
- **I/O board:** Common base board that includes various standard hardware interfaces, buttons, headers, and power-in.
- **Daughter card:** Add-on boards for supporting various features such as connectivity, debug, and other flexible I/O options.

Downloaded by Anonymous () on 12-Jan-2026 18:12:27 UTC

1.3. Astra Machina System Overview

This section covers system features, block diagrams and top views of the Astra Machina developer kit.

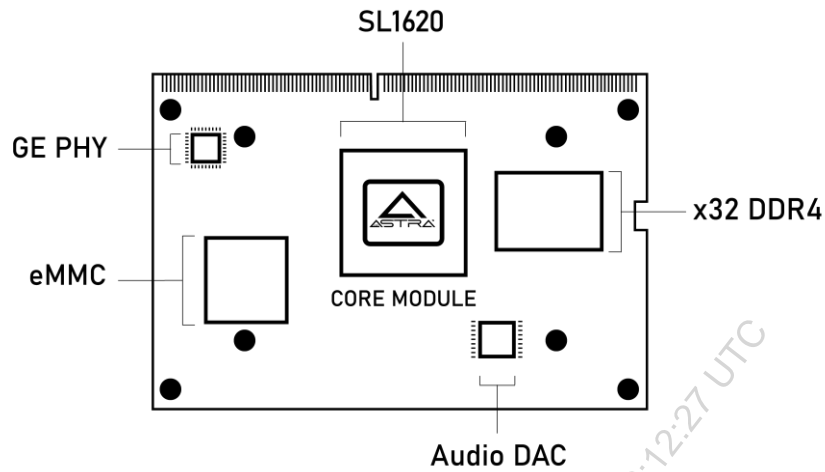

Figure 1. SL1620 core module (Dimensions: WxH = 69.6 x 47.38mm)

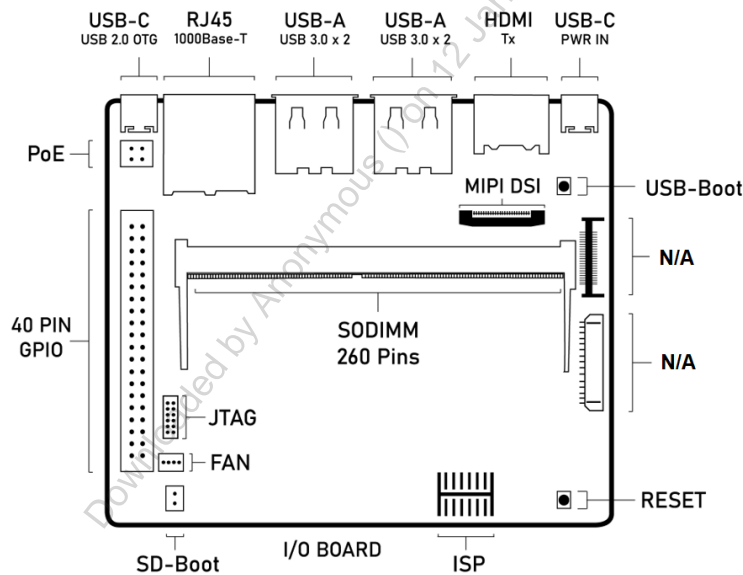

Figure 2. I/O board (Dimensions: WxH = 3937 x 3110mm)

1.3.1. Features

The SL1620-based developer kit includes the following components:

- Main components on the core module
 - Synaptics SL1620 Quad-Core Arm® Cortex®-A55 Embedded IoT Processor, up to 1.9 GHz
 - Storage: eMMC 5.1 (32 GB¹)
 - DRAM: x32 2GB system memory by 2pcs x16, 8-Gbit, DDR4-2133
 - PMIC: support DVFS in Vcore supply rail
 - MIPI DSI to HDMI 1.4 output
 - SD Card Receptacle
 - Line-out: direct Line Level 2.1-VRMS stereo output
 - DMIC: 2 digital microphones – 1 PDM stereo audio input
 - LCDC(RGB): on 54-pins FPC connector to support DPI 16/18/24bpp, or DBI MCU parallel output formats; up to 1080p30 screen resolution
- Main components on I/O board
 - M.2 E-key 2230 Receptacle: It supports SDIO, UART for WiFi/BT modules
 - USB 3.0 Type-A: 4 ports to support host mode at SuperSpeed
 - USB 2.0 Type-C: supports OTG host or peripheral mode at Hi-Speed
 - Push buttons: used for USB-BOOT selection and system RESET
 - 2pin Header: used for SD-BOOT selection
- Off-board daughter card interface options
 - MIPI DSI on 22-pin FPC interface to support 4-lane DPHY plus I2C and GPIOs for up to 1080p60 display panel
 - ISP 12-pin daughter card to support offline program SPI NOR flash on Core-Module
 - JTAG daughter card for debug
 - 40-pin header for additional functions
 - 4-pin PoE+ connector with a PoE hat board (purchased separately), it offers an add-on voltage regulator module for PoE+ Type2 (802.3at) power device. Available power shall be 25.5W (Class 4) at 5V pins of 40-pin header to I/O board.
 - 4-pin connector for active Fan with PWM
- Type-C power supply with 15V@1.8A

¹ Capacity may vary.

1.3.2. SL1620 system block diagram

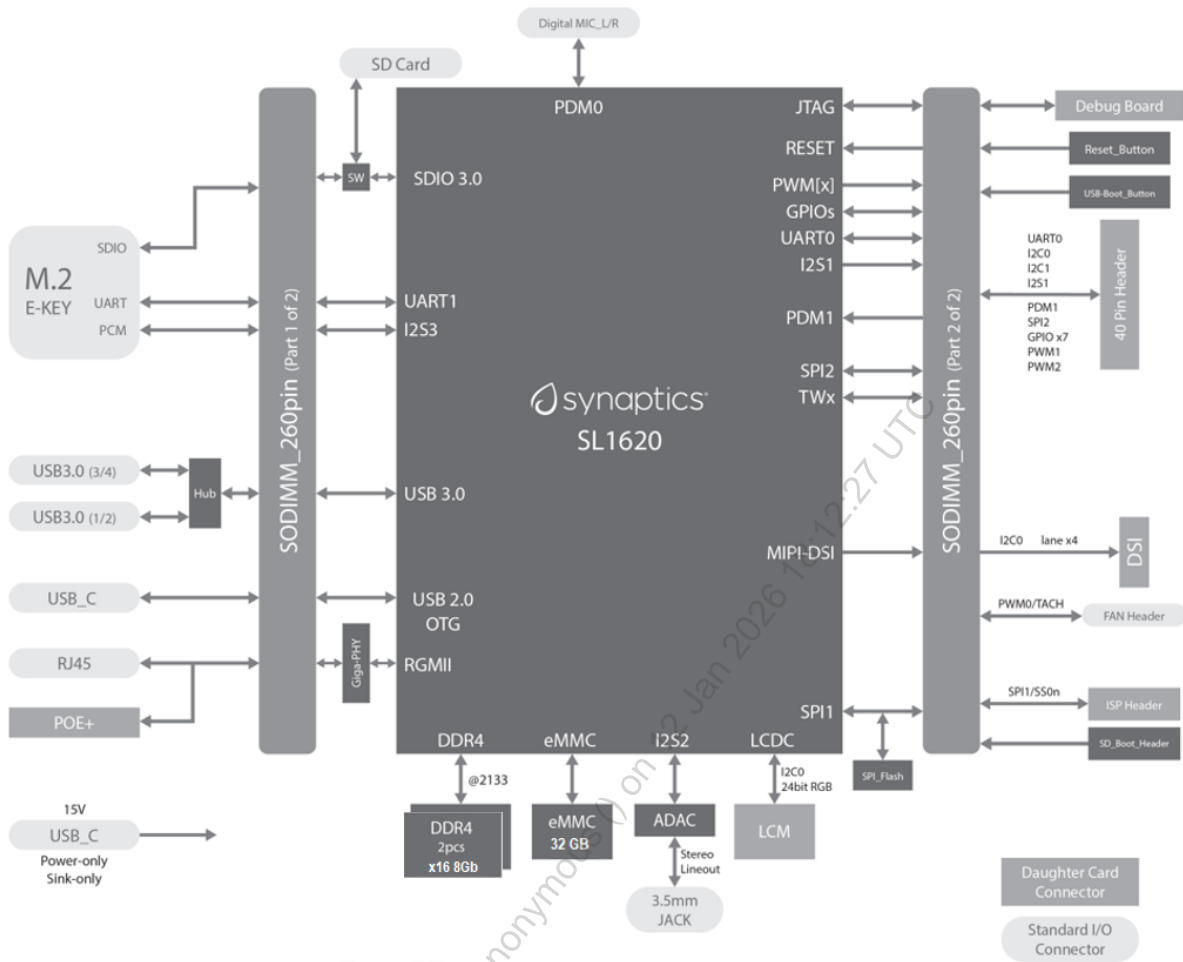

Figure 3. SL1620 system block diagram

1.3.3. Top view of SL1620 Astra Machina Developer Kit

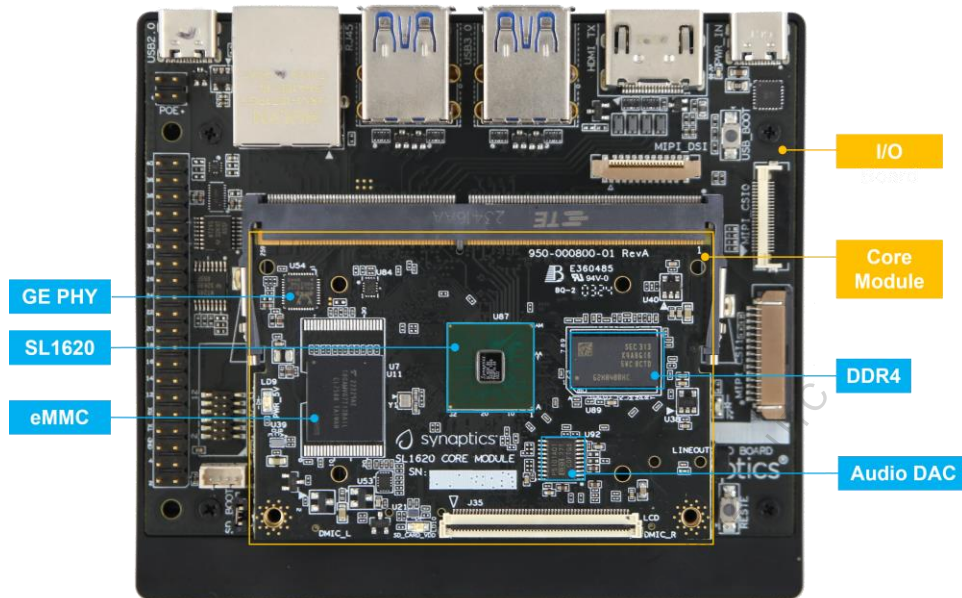

Figure 4. Top view of SL1620 developer kit

Downloaded by Anonymous () on 12 Jan 2024

1.3.4. System connectors

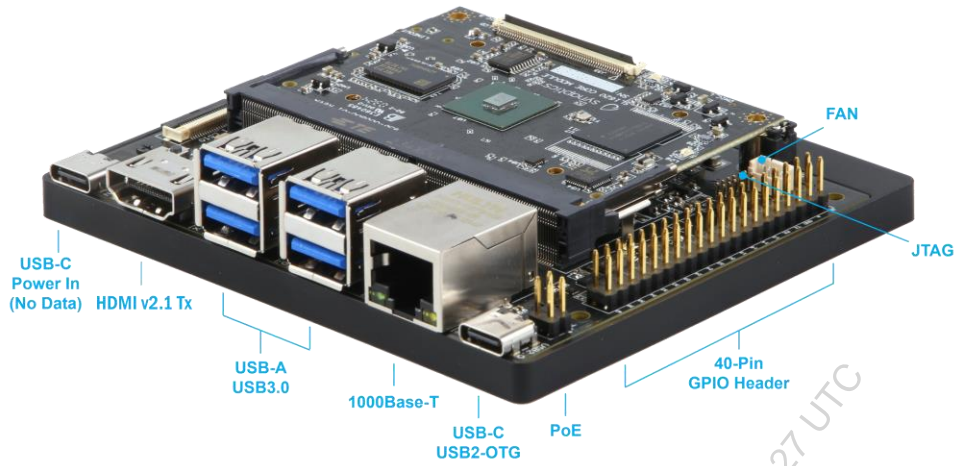

Figure 5. Front view

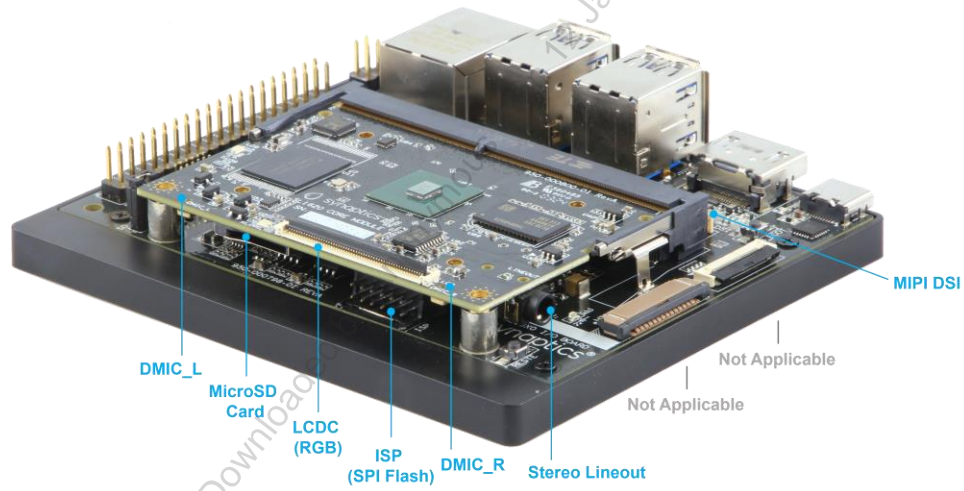

Figure 6. Rear view

2. Astra Machina Board Control/Status & System I/O

This section covers booting up, LEDs status indicators, buttons, connectors, and pin-strap settings.

2.1. Booting up

The Astra Machina supports booting from three interfaces. Users can select a boot interface before powering

up, as follows:

- **eMMC boot:** Default boot interface.
- **SD boot:** Short SD_Boot header by 2.54mm jumper-cap before power-up, see SD_Boot header in [Figure 9](#). Ensure SD-Card with firmware is plugged into SD-slot on core module in [Figure 10](#).
- **USB boot:** Connect USB-C usb2.0 port to the host PC, then follow the procedure in section [2.4](#).

Downloaded by Anonymous () on 12-Jan-2026 18:12:27 UTC

2.2. LEDs

2.2.1. LED locations

Figure 7 shows the LED locations on the I/O board.

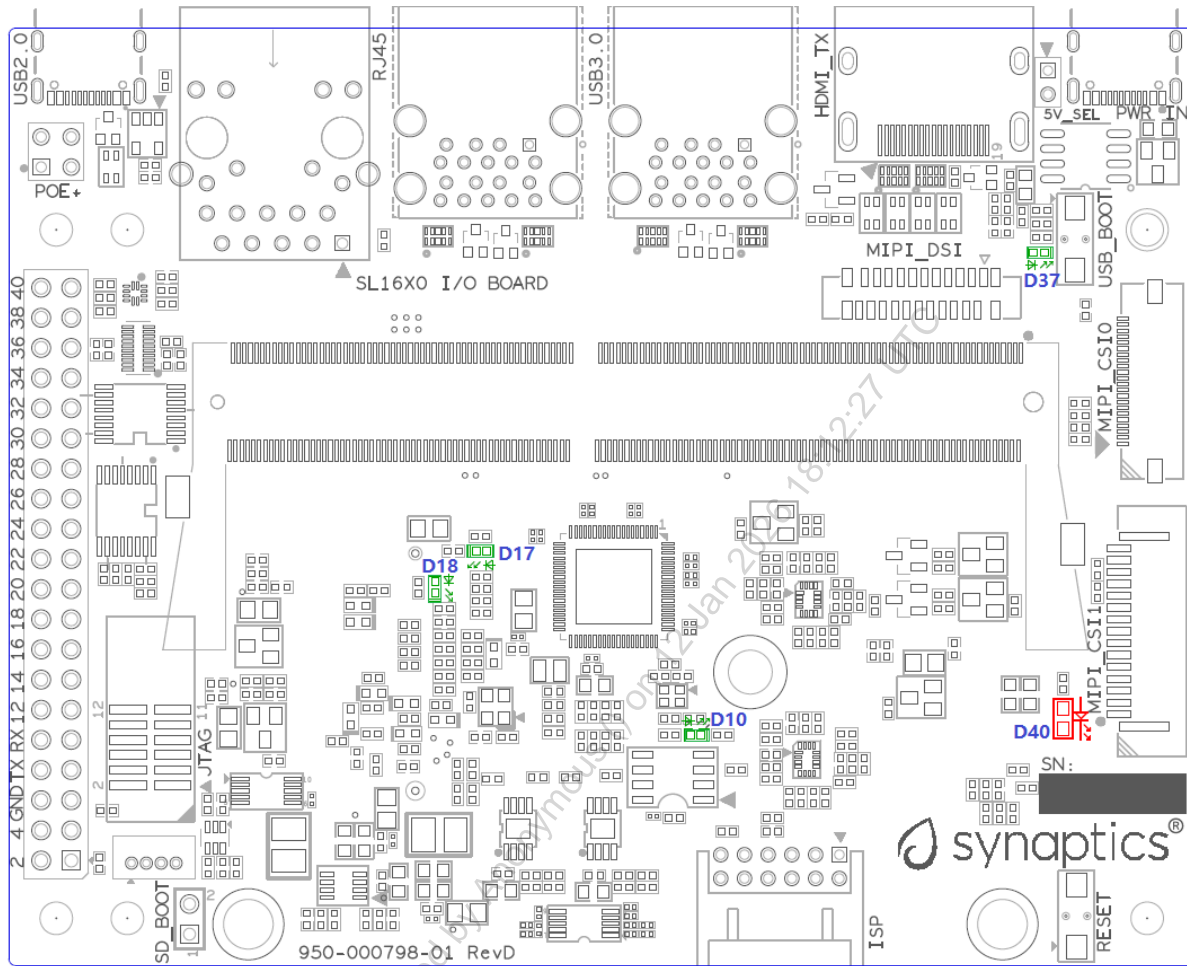

Figure 7. LED locations on I/O board

2.2.2. LED definitions

Table 1. LED definitions on I/O board

LED	Color	LEDs Function
D10	Green	LED indicator for USB3.0 Hub is working in normal mode or suspend mode.
D17	Green	LED indicator1 for M.2 device general purpose.
D18	Green	LED indicator2 for M.2 device general purpose.
D37	Green	LED indicator for Power-on status.
D40	RED	LED indicator for Stand-by status.

2.3. SoC Pinstrip and Bootup Settings

Table 2. SoC pinstrip and bootup settings on core module

Pad Name	Strap Name	Setting Value Default*	Resistor Stuffing + stuffed - removed	Description Rpu = OnChip Pull-up Rpd = OnChip Pull-down
TEST_EN	TEST_EN	—	—	SM TEST Enable (Rpd)
		0*	-R120	0: Enable ARM ICE JTAG connections (CoreSight)
		1	+R120	1: Enable SCAN or BSCAN tests
JTAG_SEL	JTAG_SEL	—	—	SM JTAG Port Selection (Rpd)
		0*	-R121	0: ARM ICE JTAG connections
		1	+R121	1: Reserved for factory use
POR_EN	POR_EN	—	—	Power-on reset (POR) bypass (Rpu)
		0	+R4	0: Bypass on-chip POR generator
		1*	-R4	1: Enable on-chip POR generator
PWM[0]	cpuRstByps	—	—	CPU reset bypass strap (Rpd)
		0*	-R116	0: Enable reset logic inside CPU partition
		1	+R116	1: Bypass reset logic inside CPU partition
SPI2_SCLK	pllPwrDown	—	—	SYS/MEM/CPU PLL Power Down; Note: pllPwrDown should be set to 1 only when pllByps is also set to 1. (Rpd)
		0*	-R123	0: Power up
		1	+R123	1: Power down
USB2_DRV_VBUS	pllByps	—	—	SYS/MEM/CPU PLL bypass indicator
		0*	-R124	0: No bypass
		1	+R124	1: All PLL bypassed
SPI2_SSON	software_strap[1]	—	—	Straps for software usage (Rpd)
		0*	-R117	—
		1	+R117	—
SPI1_SDO[0]	software_strap[2]	—	—	Straps for software usage (Rpd)
		0*	-R118	—
		1	+R118	—
SPI1_SCLK[1]	software_strap[3]	—	—	Straps for software usage (Rpd)
		0*	-R119	—
		1	+R119	—

Pad Name	Strap Name	Setting Value Default*	Resistor Stuffing + stuffed - removed	Description Rpu = OnChip Pull-up Rpd = OnChip Pull-down
I2S1_D0	boot_src[0]	—	—	CPU Boot Source bit [0] (Rpu). See boot_src[1:0]. 2'b00: SPI-Secure Boot 2'b01: ROM boot from NAND 2'b10: ROM boot from eMMC 2'b11: SPI-Clear boot
		0*	R105	ROM boot from SPI.
		1	R107	ROM boot from NAND.
I2S2_D0	boot_src[1]	—	—	CPU Boot Source bit [1] (Rpd). See boot_src[1:0]. 2'b00: SPI-Secure Boot 2'b01: ROM boot from NAND 2'b10: ROM boot from eMMC 2'b11: SPI-Clear boot
		0	R108	ROM boot from SPI.
		1*	R106	ROM boot from eMMC.
I2S3_D0	Legacy_boot	—	—	Strap to reduce reset wait time (Rpd)
		0*	-R122	0: 2 ms
		1	+R122	1: 20 ms

Table 3. Bootup settings on I/O board

Net Name	Strap Name	Setting Value Default *	Resistor Stuffing + stuffed - removed	Description Rpu = OnChip Pull-up Rpd = OnChip Pull-down
USB_BOOTn	USB-Boot	—	—	ROM code uses this strap to determine if booting from USB or not (Rpu)
		0	—	0: Boot from USB when USB-BOOT button is pressed while system reset de-assertion.
		1*	—	1: Boot from the device select by boot_src[1]
CONN-SPI.VDDIO1P8 .BOOT_SRC1	SD-Boot	—	—	ROM code uses this strap to determine if booting from SD_Card or not (Rpu)
		0	—	0: Boot from SD_Card when SD_Boot header is on while system reset de-assertion.
		1*	—	1: Boot from the device select by boot_src[1] when SD_Boot Header is off.

2.4. Hardware Manual Button Settings

Table 4. Hardware manual button settings definitions on I/O board

Switch Block	Type	Setting	Function
SW6 (RESET)	Momentary Pushbutton	Push	SL1620 Reset Key asserted
		Release	Key de-asserted
SW7(USB_BOOT)	Momentary Pushbutton	Push	USB boot Key asserted. Needs combo RESET button. Read below steps on how to enter USB-Boot mode.
		Release	Key de-asserted

To enter USB-Boot mode, follow these steps:

Note: Prior to these steps, make sure the USB driver is installed successfully on PC host side. For details, please reference the *Astra SDK Linux User Guide* available on the Synaptics GitHub.

1. Push RESET button to assert system reset to SL1620.
2. Keep pushing RESET button and push USB_BOOT button at the same time for 1-2 seconds.
3. Release RESET button while holding USB_BOOT button, so SL1620 enters USB-Boot mode.
4. Check and wait for the console print... messages.

Once the console print is returned and entered USB boot successfully, release USB_BOOT button.

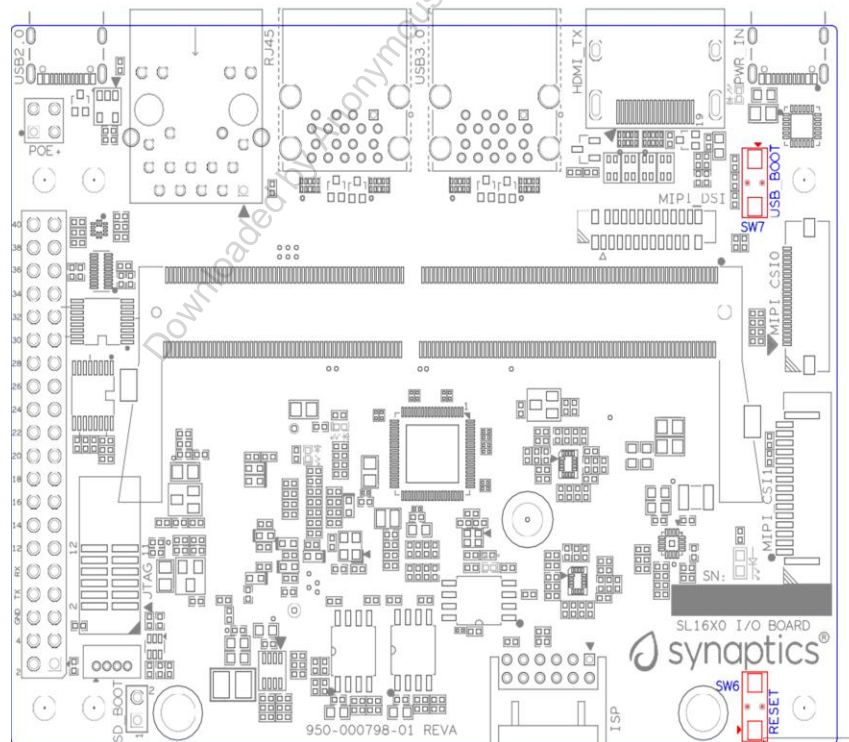

Figure 8. Locations of manual buttons on I/O board

2.5. Hardware Jumper Settings

Table 5. Hardware jumper settings definitions on I/O board

Ref Des	Type	Pin Connection	Description
JP1	2x1 2.54mm header	1-2	SD_Boot selection
			<ul style="list-style-type: none"> Open: Boot from the device select by boot_src[1]
			<ul style="list-style-type: none"> Short: Boot from SD_Card while power-up or system reset de-assertion
JP2	2x1 2mm header	1-2	5V_SEL selection
			<ul style="list-style-type: none"> Open: 15V from USB-C adapter Power-In
			<ul style="list-style-type: none"> Short: 5V from USB-C adapter Power-In

To enter SD-Boot mode, follow these steps:

Note: Prior to these steps, make sure SD-Card with firmware is plugged into SD-slot on core module.

1. Short SD_Boot header by 2.54mm jumper-cap before power-up.
2. Power-up system, then boot-up from SD_Card.

Figure 9 shows the Header locations on the I/O board.

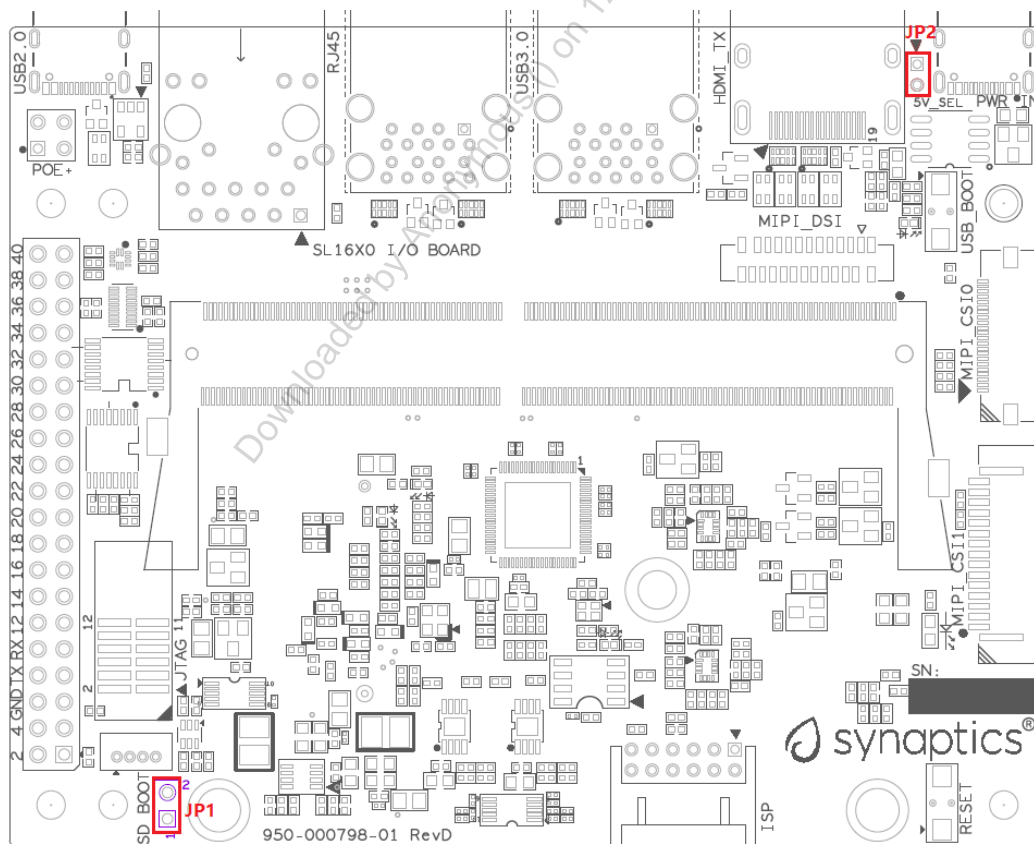

Figure 9. Locations of jumpers on I/O board

2.6.3. Core module connector definitions

Table 6. Core module connector definitions

Main Ref Des	Connecting Boards/Devices (Ref Des if any)	Functions	Remarks
J31	MicroSD Card	SDIO card	For micro-SD type of memory card extension.
J35	LCD	LCD	Connects LCD panel daughter card through 54-pin FPC cable.
J37	Line out	Analog audio L/R	Audio L/R output to 3.5mm Jack.
U2, U3	DMIC_L/R	PDM	Digital MIC_L/R input.

2.6.4. Locations of connectors on the top side of the I/O board

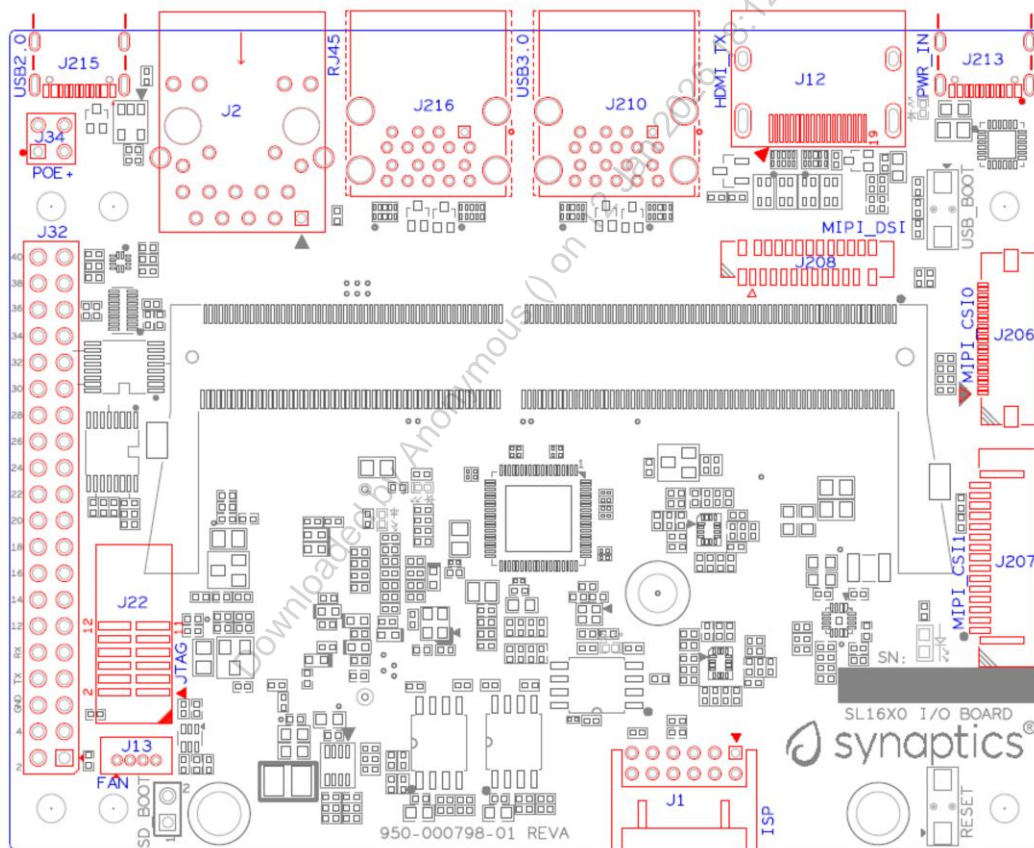

Figure 12. Locations of connectors on the top side of the I/O board

2.6.6. I/O board connector definitions

Table 7. I/O board connector definitions

Main Ref Des	Connecting Boards/Devices (Ref Des if any)	Functions	Remarks
J1	ISP D/C	SPI	12-pin daughter card to support offline program SPI NOR flash on core-module
J2	RJ45 cable	Giga Ethernet	For Wired Ethernet connection
J12	HDMI Sink	HDMI TX	For off-board HDMI Sink device connection
J13	FAN	Heat Dissipation w/ FAN	Active FAN with PWM
J17	M.2 2230 D/C	SDIO and PCIe	1x1/2x2 WiFi/Bluetooth card via SDIO PCIe is not applicable for SL1620.
J22	Debug Board	JTAG	XDB debugger for debugging
J32	40-pins Header	UART, I2C, SPI, PDM, I2S/I/O, GPIOs, STS1, PWMs, ADC	Flexible for support various D/C
J34	PoE+ D/C	PoE+	4-pin PoE+ daughter card with supporting an add-on 5V voltage to 40pin Header.
J206	MIPI-CSIO adaptor	MIPI-CSI	Not Applicable for SL1620
J207	MIPI-CSII adaptor	MIPI-CSI	Not Applicable for SL1620
J208	MIPI-DSI adaptor	MIPI-DSI	For MIPI-DSI x4 lane extension, like panel
J210	USB Device	USB 3.0 x2	For USB3.0 extension in Device mode only
J213	TypeC power source	Power Supply	Power for Astra Machina rated at 15V/1.8A
J215	USB Device	USB2.0 OTG	For USB2.0 extension, in either Host or Device mode
J216	USB Device	USB 3.0 x2	For USB3.0 extension in Device mode only

3. Daughter Cards

A set of daughter cards supplements the Astra Machina system with a variety of I/O peripheral functionalities. Perspective devices offered by different manufacturers for each of such I/O may be implemented using respective daughter card.

3.1. Debug Board

Debug board (Rev5) allows users to communicate with the SL1620 system over JTAG through a debugger on a PC host. While connecting the Astra Machina and debug board with a 20-pin flat cable, align pin-1 of the 2x10 cable socket at debug board side with pin-1 of 2x6 header J22 on the developer kit.

Users may communicate with SL1620 over UART on a PC host by using a low-cost UART to USB cable commonly available. See Astra Machina webpage for a qualified list. As an option, the debug board also provides such bridging function based on the Silicon Labs CP2102. A virtual COM port driver is required, and can be downloaded from the following link and installed on the host PC:

<https://www.silabs.com/products/development-tools/software/usb-to-uart-bridge-vcp-drivers>

UART on the developer kit and the PC host USB are digitally isolated, with no direct conductive path, eliminating ground loop and back-drive issues when either is powered down.

Figure 14 shows debug board connectivity facilitating UART and JTAG communications.

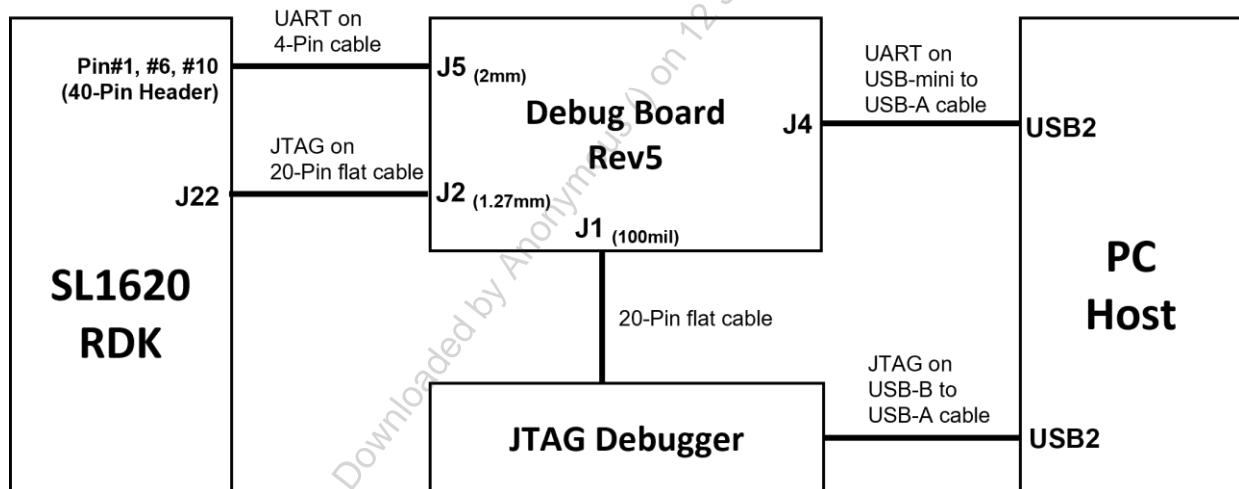

Figure 14. Debug board connectivity for UART and JTAG

3.2. M.2 Card

An M.2 E-Key socket J17 is provided for a variety of modules in the M.2 form factor. Typical applicable modules support Wi-Fi/BT devices with SDIO or PCIe signal interfaces.

Available module:

- Ampak AP12611_M2 with SYN43711 WiFi6E/BT5.3 1x1 over SDIO on M.2 adaptor

3.3. 260-Pins SODIMM definition

A 260-Pins SODIMM connector (PN: TE_2309413-1) joins the core module and the I/O board. [Table 8](#) shows the assignment for the 260-Pins.

Table 8. 260-pins SODIMM definition

Assignment	Pin#	260-Pins SODIMM	Pin#	Assignment
GePHY_RSTn (From IO_Exp)	2		1	n/a
SPI1_SDO && STRP[SS2]	4		3	n/a
SPI1_SCLK && STRP[SS3]	6		5	n/a
LCD_RSTn (From IO_EXP)	8		7	n/a
n/a	10		9	n/a
SPI1_SDI	12		11	n/a
SPI1_SSO n	14		13	n/a
External_Boot_SRCO	16		15	n/a
n/a	18		17	n/a
SD-CARD_PPWR_EN	20		19	n/a
SD-CARD_VIO_SEL	22		21	n/a
LCD_TP_IRQ	24		23	n/a
GND	26		25	n/a
n/a	28		27	n/a
n/a	30		29	n/a
GND	32		31	n/a
n/a	34		33	n/a
n/a	36		35	n/a
GND	38		37	n/a
n/a	40		39	n/a
n/a	42		41	n/a
GND	44		43	n/a
USB2_Dn	46		45	n/a
USB2_Dp	48		47	n/a
GND	50		49	n/a
USB3_RXp	52		51	n/a
USB3_RXn	54		53	GND
GND	56		55	n/a
USB3_TXp	58		57	n/a
USB3_TXn	60		59	GND
GND	62		61	n/a
USB3_USB20.Dp	64		63	n/a

Assignment	Pin#	260-Pins SODIMM	Pin#	Assignment
USB3_USB20.Dn	66		65	GND
GND	68		67	n/a
USB2_IDPIN	70		69	n/a
PWR_OTG_VBUS	72		71	GND
PWR_USB3_VBUS	74		73	n/a
I2S3_BCLK	76		75	n/a
I2S3_DI	78		77	GND
I2S3_DO	80		79	n/a
I2S3_LRCK	82		81	n/a
I2S1_DI	84		83	GND
GPIO[22]	86		85	n/a
PDM_DI[1]	88		87	n/a
PDM_CLKIO	90		89	GND
TW1_SCL	92		91	n/a
TW1_SDA	94		93	n/a
GPIO-EXP_O_2	96		95	GND
FAN_TACH_Control	98		97	n/a
n/a	100		99	n/a
FAN_PWM	102		101	GND
I2S1_BCLK	104		103	n/a
EXPANDER_INT-REQn	106		105	n/a
BOOT_SRC1	108		107	GND
I2S1_DO0	110		109	n/a
I2S1_MCLK	112		111	n/a
I2S1_LRCK	114		113	GND
PWM2	116		115	MIPI_DSI_TDO _n
GPIO[2]	118		117	MIPI_DSI_TDO _p
URTO_TXD	120		119	GND
URTO_RXD	122		121	MIPI_DSI_TD1 _n
SPI2_SDI	124		123	MIPI_DSI_TD1 _p
SPI2_SCLK	126		125	GND
SPI2_SDO	128		127	MIPI_DSI_TCK _p
SPI2_SS3 _n	130		129	MIPI_DSI_TCK _n
USB2_OC _n	132		131	GND
SPI2_SS1 _n	134		133	MIPI_DSI_TD3 _n
SPI2_SSO _n	136		135	MIPI_DSI_TD3 _p
TW1_SDA	138		137	GND

Assignment	Pin#	260-Pins SODIMM	Pin#	Assignment
TW1_SCL	140		139	MIPI_DSI_TD2p
n/a	142		141	MIPI_DSI_TD2n
n/a	144		143	GND
SPI2_SDO_3V3	146		145	GND
SPI2_SDI_3V3	148		147	LT9611-HDMI_TX_CKn
SPI2_CLK_3V3	150		149	LT9611-HDMI_TX_CKp
n/a	152		151	GND
USB-C_Logic_INTn	154		153	LT9611-HDMI_TX_DOn
n/a	156		155	LT9611-HDMI_TX_DOp
n/a	158		157	GND
Levershift_EN# for 40P header	160		159	LT9611-HDMI_TX_D1n
n/a	162		161	LT9611-HDMI_TX_D1p
RSTIn@PU	164		163	GND
JTAG_TDO	166		165	LT9611-HDMI_TX_D2n
JTAG_TDI.SoC_WakeUp#	168		167	LT9611-HDMI_TX_D2p
JTAG_TMS	170		169	GND
n/a	172		171	n/a
n/a	174		173	n/a
GPIO[48]	176		175	GND
TW2_SDA	178		177	HDMI_PWR_EN
TW2_SCL	180		179	JTAG_TCK
TWO_SDA	182		181	GPIO[47]
TWO_SCL	184		183	JTAG_TRSTn
URT1A_CTSn for M.2	186		185	GPIO-EXP_O_7
URT1A_RTSn for M.2	188		187	URT1A_RXD for M.2
PWM1	190		189	GPIO[55]
GND	192		191	URT1A_TXD for M.2
PWR_1V8	194		193	n/a
PWR_1V8	196		195	n/a
PWR_1V8_CTL	198		197	n/a
PWR_1V8_CTL	200		199	n/a
PWR_3V3_CTL	202		201	n/a
PWR_3V3_CTL	204		203	n/a
GND	206		205	USB_BOOTn
M.2_WIFI_SDIO_CLK	208		207	SDIO_MUX_SEL (From IO_EXP)
GND	210		209	ETHERNET_LINK_LED
M.2_WIFI_SDIO_CMD	212		211	ETHERNET_DUPLX_LED

Assignment	Pin#	260-Pins SODIMM	Pin#	Assignment
GND	214		213	GND
M.2_WIFI_SDIO_D0	216		215	RJ45_MDIPO
GND	218		217	RJ45_MDINO
M.2_WIFI_SDIO_D1	220		219	GND
GND	222		221	RJ45_MDIP1
M.2_WIFI_SDIO_D2	224		223	RJ45_MDIN1
GND	226		225	GND
M.2_WIFI_SDIO_D3	228		227	RJ45_MDIP2
GND	230		229	RJ45_MDIN2
PWR_3V3	232		231	GND
PWR_3V3	234		233	RJ45_MDIP3
PWR_3V3	236		235	RJ45_MDIN3
PWR_3V3	238		237	GND
PWR_3V3	240		239	PWR_BL for LCD backlight
PWR_3V3	242		241	PWR_BL for LCD backlight
GND	244		243	GND
GND	246		245	GND
GND	248		247	GND
GND	250		249	GND
PWR_5V	252		251	PWR_5V
PWR_5V	254		253	PWR_5V
PWR_5V	256		255	PWR_5V
PWR_5V	258		257	PWR_5V
PWR_5V	260		259	PWR_5V

3.4. 40-Pins Header

A 40-pins GPIO header with 0.1-inch (2.54mm) pin pitch is on the top edge of the I/O board. Any of the general-purpose 3.3V pins can be configured in software with a variety of alternative functions. For additional information, please refer to the *SL1620 Datasheet*.

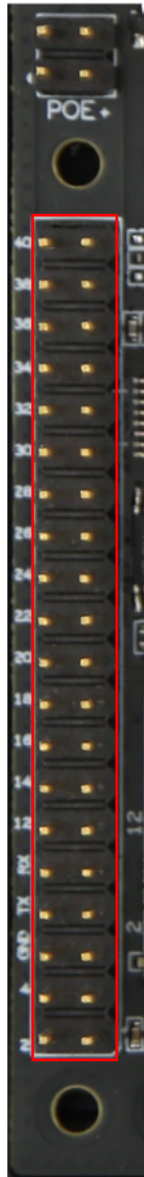

SL1620 RDK 40-Pin Header Definition					
I2S1_DO	40	●	●	39	GND
I2S1_BCLK	38	●	●	37	I2S1_MCLK
SPI2_SS3n	36	●	●	35	I2S1_LRCK
GND	34	●	●	33	CM_GPIO-EXP_O_7
GPIO47	32	●	●	31	GPIO48
GND	30	●	●	29	GPIO22
PDM_DI[1]	28	●	●	27	PDM_CLKIO
SPI2_SS1n	26	●	●	25	GND
SPI2_SS0n	24	●	●	23	SPI2_CLK
GPIO55	22	●	●	21	SPI2_SDI
GND	20	●	●	19	SPI2_SDO
GPIO2	18	●	●	17	3.3V
PWM[2]	16	●	●	15	I2S1_DI
GND	14	●	●	13	TW1_SDA
CM_GPIO-EXP_O_2	12	●	●	11	TW1_SCL
URTO_RX	10	●	●	9	GND
URTO_TX	8	●	●	7	PWM[1]
GND	6	●	●	5	TWOA_SCL
5.0V	4	●	●	3	TWOA_SDA
5.0V	2	●	■	1	3.3V

Figure 15. 40-pins header definition

3.5. Pin-demuxing for Standard Interface Configuration

This section covers pin-demuxing configuration for the SL1620 developer kit.

For System on Chip (SoC), see [Table 9](#).

Table 9. SoC pin-demuxing usage

SL1620 System-on-chip (SoC) Domain				
	Pad/Pin Name	Default Usage	Direction	Mode Setting
SDIO	SDIO_CDn	I:SDIOA_CDn	IN	MODE_1
	SDIO_WP	IO:GPIO[55]	IN/OUT	MODE_0
SPI1	SPI1_SSn	O:SPI1_SSn	OUT	MODE_0
	SPI1_SS1n	IO:GPIO[4]	IN	MODE_2
	SPI1_SS2n	I:URTOA_RXD	IN	MODE_0
	SPI1_SS3n	O:URTOA_TXD	OUT	MODE_0
	SPI1_SDO	O:SPI1_SDO	OUT	MODE_0
	SPI1_SDI	I:SPI1_SDI	IN	MODE_0
	SPI1_SCLK	O:SPI1_SCLK	OUT	MODE_0
SPI2	SPI2_SSn	O:SPI2_SSn	OUT	MODE_1
	SPI2_SS1n	O:SPI2_SS1n	OUT	MODE_1
	SPI2_SS2n	O:SPI2_SS2n	OUT	MODE_2
	SPI2_SS3n	O:SPI2_SS3n	OUT	MODE_2
	SPI2_SDO	O:SPI2_SDO	OUT	MODE_1
	SPI2_SDI	I:SPI2_SDI	IN	MODE_1
	SPI2_SCLK	O:SPI2_SCLK	OUT	MODE_1
UART	URT1_RXD	I:URT1A_RXD	IN	MODE_2
	URT1_TXD	O:URT1A_TXD	OUT	MODE_2
TWSI	TWO_SCL	IO:TWOA_SCL	OUT	MODE_0
	TWO_SDA	IO:TWOA_SDA	IN/OUT	MODE_0
	TW1_SCL	IO:TW1_SCL	OUT	MODE_0
	TW1_SDA	IO:TW1_SDA	IN/OUT	MODE_0
	TW2_SCL	IO:TW2_SCL	OUT	MODE_1
	TW2_SDA	IO:TW2_SDA	IN/OUT	MODE_1
	TW3_SCL	O:URT1A_RTSn	OUT	MODE_2
	TW3_SDA	I:URT1A_CTSn	IN	MODE_2
USB2	USB2_DRV_VBUS	O:GPIO[51]	OUT	MODE_1
PWM	PWM[0]	O:PWM[0]	OUT	MODE_1

SL1620 System-on-chip (SoC) Domain				
Pad/Pin Name	Default Usage	Direction	Mode Setting	
	PWM[1]	O:PWM[1]	OUT	MODE_1
	PWM[2]	O:PWM[2]	OUT	MODE_1
	PWM[3]	O:PWM[3]	OUT	MODE_1
RGMII	RGMII_TXC	O:RGMII_TXC	OUT	MODE_1
	RGMII_TXD[0]	O:RGMII_TXD[0]	OUT	MODE_1
	RGMII_TXD[1]	O:RGMII_TXD[1]	OUT	MODE_1
	RGMII_TXD[2]	O:RGMII_TXD[2]	OUT	MODE_1
	RGMII_TXD[3]	O:RGMII_TXD[3]	OUT	MODE_1
	RGMII_TXCTL	O:RGMII_TXCTL	OUT	MODE_1
	RGMII_RXC	I:RGMII_RXC	IN	MODE_1
	RGMII_RXD[0]	I:RGMII_RXD[0]	IN	MODE_1
	RGMII_RXD[1]	I:RGMII_RXD[1]	IN	MODE_1
	RGMII_RXD[2]	I:RGMII_RXD[2]	IN	MODE_1
	RGMII_RXD[3]	I:RGMII_RXD[3]	IN	MODE_1
	RGMII_RXCTL	I:RGMII_RXCTL	IN	MODE_1
I2S1	I2S1_DO	O:I2S1_DO	OUT	MODE_1
	I2S1_DI	I:I2S1_DI	IN	MODE_1
	I2S1_LRCK	IO:I2S1_LRCK	IN/OUT	MODE_1
	I2S1_BCLK	IO:I2S1_BCLK	IN/OUT	MODE_1
	I2S1_MCLK	IO:I2S1_MCLK	OUT	MODE_1
I2S2	I2S2_DO	O:I2S2_DO	OUT	MODE_1
	I2S2_DI	IO:GPIO[22]	IN/OUT	MODE_0
	I2S2_LRCK	IO:I2S2_LRCK	IN/OUT	MODE_1
	I2S2_BCLK	IO:I2S2_BCLK	IN/OUT	MODE_1
I2S3	I2S3_DO	O:I2S3_DO	OUT	MODE_1
	I2S3_DI	I:I2S3_DI	IN	MODE_1
	I2S3_LRCK	IO:I2S3_LRCK	IN/OUT	MODE_1
	I2S3_BCLK	IO:I2S3_BCLK	IN/OUT	MODE_1
PDM	PDM_CLKIO	IO:PDM_CLKIO	OUT	MODE_1
	PDM_DI[0]	I:PDM_DI[0]	IN	MODE_1
	PDM_DI[1]	I:PDM_DI[1]	IN	MODE_1
JTAG	TMS	IO:GPIO[0]	IN	MODE_1
	TDI	IO:GPIO[1]	IN	MODE_1

SL1620 System-on-chip (SoC) Domain				
Pad/Pin Name		Default Usage	Direction	Mode Setting
	TDO	IO:GPIO[2]	IN/OUT	MODE_1
GPIO_A	GPIO_A[0]	IO:RGMIIA_MDIO	IN/OUT	MODE_1
	GPIO_A[1]	O:RGMIIA_MDC	OUT	MODE_1
	GPIO_A[2]	IO:GPIO[48]	IN/OUT	MODE_0
	GPIO_A[3]	IO:GPIO[47]	IN/OUT	MODE_0
NAND	NFALE	O:NFALE	OUT	MODE_1
	NFLCS	O:NFLCS	OUT	MODE_1
LCDC	LCDD0	IO:LCDD0	IN/OUT	MODE_1
	LCDD1	IO:LCDD1	IN/OUT	MODE_1
	LCDD2	IO:LCDD2	IN/OUT	MODE_1
	LCDD3	IO:LCDD3	IN/OUT	MODE_1
	LCDD4	IO:LCDD4	IN/OUT	MODE_1
	LCDD5	IO:LCDD5	IN/OUT	MODE_1
	LCDD6	IO:LCDD6	IN/OUT	MODE_1
	LCDD7	IO:LCDD7	IN/OUT	MODE_1
	LCDD8	IO:LCDD8	IN/OUT	MODE_1
	LCDD9	IO:LCDD9	IN/OUT	MODE_1
	LCDD10	IO:LCDD10	IN/OUT	MODE_1
	LCDD11	IO:LCDD11	IN/OUT	MODE_1
	LCDD12	IO:LCDD12	IN/OUT	MODE_1
	LCDD13	IO:LCDD13	IN/OUT	MODE_1
	LCDD14	IO:LCDD14	IN/OUT	MODE_1
	LCDD15	IO:LCDD15	IN/OUT	MODE_1
	LCDD16	IO:LCDD16	IN/OUT	MODE_1
	LCDD17	IO:LCDD17	IN/OUT	MODE_1
	LCDD18	IO:LCDD18	IN/OUT	MODE_1
	LCDD19	IO:LCDD19	IN/OUT	MODE_1
	LCDD20	IO:LCDD20	IN/OUT	MODE_1
	LCDD21	IO:LCDD21	IN/OUT	MODE_1
	LCDD22	IO:LCDD22	IN/OUT	MODE_1
	LCDD23	IO:LCDD23	IN/OUT	MODE_1
	LPCLK	O:LPCLK	OUT	MODE_1
	LCDGPIO0	O:LCDGPIO0	OUT	MODE_1

SL1620 System-on-chip (SoC) Domain				
Pad/Pin Name		Default Usage	Direction	Mode Setting
	LCDGPIO1	O:LCDGPIO1	OUT	MODE_1
	LCDGPIO2	O:LCDGPIO2	OUT	MODE_1
	LCDGPIO3	O:LCDGPIO3	OUT	MODE_1

Downloaded by Anonymous () on 12-Jan-2026 18:12:27 UTC

3.6. Pin-demuxing for GPIO/GPO Configuration

This section covers pin-demuxed GPIO/GPO usage of SoC domains.

Table 10. SoC GPIO/GPO usage

SL1620 SoC GPIO/GPO	Availability	Direction	Default Function	GPIO Signaling
GPIO[0]	MODE_1	IN	GPIO_EXP_INTn (CM)	0: GPIO Expander triggers interrupt (Core Module) 1: No interrupt
GPIO_X[0]	Not Available	IN/OUT	IO:LCDD8	—
GPIO[1]	MODE_1	IN	WiFi_WAKE_UP#	0: Wake up triggered by WiFi 1: No wake up trigger
GPIO_X[1]	Not Available	IN/OUT	IO:LCDD9	—
GPIO[2]	MODE_1	IN/OUT	IO:LCDD16	To 40-Pin header
GPIO_X[2]	Not Available	IN/OUT	O:SM_FE_LED[0]	—
GPIO[3]	Not Available	OUT	O:SPI1_SSO _n	—
GPIO[4]	MODE_2	IN	GPIO_EXP_INTn (I/O Board)	0: GPIO Expander triggers interrupt (I/O Board) 1: No interrupt
GPIO[5]	MODE_0	IN	I:URTOA_RXD	To 40-Pin header
GPIO[6]	MODE_0	OUT	O:URTOA_TXD	To 40-Pin header
GPO[7]	Not Available	OUT	O:SPI1_SDO	—
GPO[8]	Not Available	OUT	O:SPI1_SCLK	—
GPIO[9]	Not Available	IN	I:SPI1_SDI	—
GPIO[10]	MODE_0	OUT	IO:TWOA_SCL	To 40-Pin Header/ Display IF/ GPIO_EXP_CM
GPIO_X[10]	Not Available	IN/OUT	O:LCDGPIO3	—
GPIO[11]	MODE_0	IN/OUT	IO:TWOA_SDA	To 40-Pin Header/ Display IF/ GPIO_EXP_CM
GPIO_X[11]	MODE_0	IN	GePHY_INTB	0: Interrupt is triggered by GePHY 1: No interrupt
GPIO[12]	MODE_0	OUT	IO:TW1_SCL	To 40-Pin Header/ M.2/ GPIO_EXP_IO
GPIO_X[12]	Not Available	IN/OUT	IO:LCDD0	—
GPIO[13]	MODE_0	IN/OUT	IO:TW1_SDA	To 40-Pin Header/ M.2/ GPIO_EXP_IO
GPIO_X[13]	Not Available	IN/OUT	IO:LCDD1	—

SL1620 SoC	Availability	Direction	Default Function	GPIO Signaling
GPIO/GPO				
GPIO[14]	MODE_1	OUT	IO:I2S1_LRCK	To 40-Pin Header
GPIO_X[14]	Not Available	IN/OUT	IO:LCDD23	—
GPIO[15]	MODE_1	OUT	IO:I2S1_BCLK	To 40-Pin Header
GPIO_X[15]	Not Available	OUT	O:LPCLK	—
GPO[16]	MODE_1	OUT	O:I2S1_DO	To 40-Pin Header
GPIO_X[16]	Not Available	OUT	O:LCDGPIO0	—
GPIO[17]	MODE_1	OUT	IO:I2S1_MCLK	To 40-Pin Header
GPIO_X[17]	Not Available	OUT	O:LCDGPIO1	—
GPIO[18]	MODE_1	IN	I:I2S1_DI	To 40-Pin Header
GPIO_X[18]	Not Available	OUT	O:LCDGPIO2	—
GPIO[19]	Not Available	OUT	IO:I2S2_LRCK	—
GPIO_X[19]	Not Available	OUT	O:RGMII_TXD[0]	—
GPIO[20]	Not Available	OUT	IO:I2S2_BCLK	—
GPIO_X[20]	Not Available	OUT	O:RGMII_TXD[1]	—
GPO[21]	Not Available	OUT	O:I2S2_DO	—
GPIO_X[21]	Not Available	OUT	O:RGMII_TXD[2]	—
GPIO[22]	MODE_0	IN/OUT	IO:GPIO[22]	To 40-Pin Header
GPIO_X[22]	Not Available	OUT	O:RGMII_TXD[3]	—
GPIO[23]	MODE_1	IN	I:PDM_DI[1]	To 40-Pin Header
GPIO[24]	Not Available	IN	I:PDM_DI[0]	—
GPIO[25]	MODE_1	OUT	IO:PDM_CLKIO	To 40-Pin Header/ DMIC on Board
GPIO[26]	Not Available	OUT	IO:I2S3_LRCK	—
GPIO[27]	Not Available	OUT	IO:I2S3_BCLK	—
GPO[28]	Not Available	OUT	O:I2S3_DO	—
GPIO[29]	Not Available	IN	I:I2S3_DI	—
GPO[30]	MODE_1	OUT	O:SPI2_SSn	To 40-Pin Header
GPIO[31]	MODE_1	OUT	O:SPI2_SS1n	To 40-Pin Header
GPIO_X[31]	Not Available	IN	I:RGMII_RXD[0]	—
GPIO[32]	Not Available	OUT	O:SPI2_SS2n	—
GPIO_X[32]	Not Available	IN	I:RGMII_RXD[1]	—
GPIO[33]	MODE_2	OUT	O:SPI2_SS3n	To 40-Pin Header
GPIO_X[33]	Not Available	IN	I:RGMII_RXD[2]	—
GPO[34]	MODE_1	OUT	O:SPI2_SDO	To 40-Pin Header/ LCDC

SL1620 SoC	Availability	Direction	Default Function	GPIO Signaling
GPIO/GPO				
GPO[35]	MODE_1	OUT	O:SPI2_SCLK	To 40-Pin Header/ LCDC
GPIO[36]	MODE_1	IN	I:SPI2_SDI	To 40-Pin Header/ LCDC
GPIO[37]	Not Available	OUT	IO:TW2_SCL	—
GPIO[38]	Not Available	IN/OUT	IO:TW2_SDA	—
GPIO[39]	Not Available	IN	I:URT1A_RXD	—
GPIO_X[39]	Not Available	IN/OUT	IO:LCDD17	—
GPIO[40]	Not Available	OUT	O:URT1A_TXD	—
GPIO_X[40]	Not Available	IN/OUT	IO:LCDD22	—
GPIO[41]	Not Available	OUT	O:URT1A_RTSn	—
GPIO_X[41]	Not Available	IN	I:RGMII_RXD[3]	—
GPIO[42]	Not Available	IN	I:URT1A_CTSn	—
GPIO_X[42]	Not Available	IN	I:RGMII_RXC	—
GPIO[43]	Not Available	OUT	O:PWM[3]	—
GPIO_X[43]	Not Available	OUT	O:RGMII_TXC	—
GPIO[44]	MODE_1	OUT	O:PWM[2]	To 40-Pin Header
GPIO[45]	MODE_1	OUT	O:PWM[1]	To 40-Pin Header
GPO[46]	Not Available	OUT	O:PWM[0]	—
GPIO[47]	MODE_0	IN/OUT	IO:GPIO[47]	To 40-Pin Header
GPIO[48]	MODE_0	IN/OUT	IO:GPIO[48]	To 40-Pin Header
GPIO[49]	Not Available	OUT	O:RGMIIA_MDC	—
GPIO[50]	Not Available	IN/OUT	IO:RGMIIA_MDIO	—
GPIO[51]	MODE_1	OUT	Audio_Mute	O: Mute
				1: un-Mute
GPIO_X[51]	Not Available	OUT	O:RGMII_TXCTL	—
GPIO[52]	Not Available	OUT	O:NFALE	—
GPIO_X[52]	Not Available	IN	I:RGMII_RXCTL	—
GPIO[53]	Not Available	OUT	O:NFLCS	—
GPIO_X[53]	Not Available	IN	O:RGMII_CLK_OUT	—
GPO[54]	Not Available	IN	I:SDIOA_CDn	—
GPIO[55]	MODE_0	IN/OUT	IO:GPIO[55]	To 40-Pin Header
GPIO[56]	Not Available	IN/OUT	IO:LCDD2	—
GPIO[57]	Not Available	IN/OUT	IO:LCDD3	—
GPIO[58]	Not Available	IN/OUT	IO:LCDD4	—

SL1620 SoC	Availability	Direction	Default Function	GPIO Signaling
GPIO/GPO				
GPIO[59]	Not Available	IN/OUT	IO:LCDD5	—
GPIO[60]	Not Available	IN/OUT	IO:LCDD6	—
GPIO[61]	Not Available	IN/OUT	IO:LCDD7	—
GPIO[62]	Not Available	IN/OUT	IO:LCDD10	—
GPIO[63]	Not Available	IN/OUT	IO:LCDD11	—
GPIO[64]	Not Available	IN/OUT	IO:LCDD12	—
GPIO[65]	Not Available	IN/OUT	IO:LCDD13	—
GPIO[66]	Not Available	IN/OUT	IO:LCDD14	—
GPIO[67]	Not Available	IN/OUT	IO:LCDD15	—
GPIO[68]	Not Available	IN/OUT	IO:LCDD18	—
GPIO[69]	Not Available	IN/OUT	IO:LCDD19	—
GPIO[70]	Not Available	IN/OUT	IO:LCDD20	—
GPIO[71]	Not Available	IN/OUT	IO:LCDD21	—

Downloaded by Anonymous () on 12 Jan 2026 18:12:27 UTC

3.7. GPIO Expanders Over I2C

Due to the considerable number of functionalities covered by the SL1620 developer kit, most of the SL1620 digital pins that have GPIO/GPO pin-demux options are used for other functions. As such, GPIO expanders are used extensively to supplement system control purposes.

Table 11. GPIO expanders usage

Expander GPIO/GPO	I2C#	Domain	Voltage	Direction	Function	GPIO Signaling
GPIO0_0	TW1 (0x43)	SoC	3.3V	OUT	SDIO-MUX_SEL	0: Switch SDIO to M.2 WiFi
						1: Switch SDIO to SD Card Slot
GPIO0_1	TW1 (0x43)	SoC	3.3V	OUT	PWR_ON_DSI	0: Power OFF DSI panel
						1: Power ON DSI panel
GPIO0_2	TW1 (0x43)	SoC	3.3V	OUT	LCD_RST#	0: Reset LCD
						1: De-assert Reset
GPIO0_3	TW1 (0x43)	SoC	3.3V	OUT	GePHY_RST#	0: Reset
						1: De-assert Reset
GPIO0_4	TW1 (0x43)	SoC	3.3V	OUT	STAND-BY_EN	0: Normal playback
						1: Entry to Stand-By status with peripherals Powered down
GPIO0_5	TW1 (0x43)	SoC	3.3V	IN	USB2.0_PWR_EN	0: Power OFF
						1: Power ON
GPIO0_6	TW1 (0x43)	SoC	3.3V	IN	Not used	--
						--
GPIO0_7	TW1 (0x43)	SoC	3.3V	IN/OUT	GPIO_DSI	In reserved
						In reserved
GPIO1_0	TW1 (0x44)	SoC	3.3V	IN	USB-C_Logic_INT#	0: Status changed
						1: Status not changed
GPIO1_1	TW1 (0x44)	SoC	3.3V	OUT	Not used	--
						--
GPIO1_2	TW1 (0x44)	SoC	3.3V	OUT	M2-W_DISABLE1#	0: Disable M.2 module by DISABLE1#
						1: De-assertion
GPIO1_3	TW1 (0x44)	SoC	3.3V	OUT	M2-W_HOST-WAKE#	0: Assertion Wake-up event from Host to M.2 module
						1: De-assertion
GPIO1_4	TW1 (0x44)		3.3V	OUT	SD-CARD_PWR_EN	0: Power OFF SD card slot

Expander GPIO/GPO	I2C#	Domain	Voltage	Direction	Function	GPIO Signaling
		SoC				1: Power ON SD card slot
GPIO1_5	TW1 (0x44)	SoC	3.3V	OUT	M2-W_DISABLE2#	0: Disable M.2 module by DISABLE2# 1: De-assertion
GPIO1_6	TW1 (0x44)	SoC	3.3V	OUT	SD-CARD_VIO_SEL	0: 1.8V 1: 3.3V
GPIO1_7	TW1 (0x44)	SoC	3.3V	OUT	LCD_TP_IRQ#	0: Interrupt is triggered 1: No interrupt
GPIO0_0	TWO (0x43)	SoC	1.8V	IN	FAN_TECH_CON	0: Fan gets Error 1: No interrupt
GPIO0_1	TWO (0x43)	SoC	1.8V	IN	AUD_JACK_DET	0: Audio Jack exist 1: No Audio Jack
GPIO0_2	TWO (0x43)	SoC	1.8V	IN/OUT	GPIO_O_2 (40-Pin Header)	0: Depends on user definition 1: Depends on user definition
GPIO0_3	TWO (0x43)	SoC	1.8V	OUT	NAND_WP#	0: Write protection 1: Write accessible
GPIO0_4	TWO (0x43)	SoC	1.8V	OUT	DMIC_MUTE#	0: Mute DMIC 1: De-Mute DMIC
GPIO0_5	TWO (0x43)	SoC	1.8V	OUT	LevelTranslator_EN#	0: Enable Level translator 1: Disable Level translator
GPIO0_6	TWO (0x43)	SoC	1.8V	IN	USB2_CONN_OC#	0: Detect USB2 Over-Current 1: Normal status
GPIO0_7	TWO (0x43)	SoC	1.8V	IN/OUT	GPIO_O_7 (40-Pin Header)	0: Depends on user definition 1: Depends on user definition

3.8. I2C Bus

This section describes the Astra Machina's usage of the I²C bus, the equivalence of SL1620's Two Wire Serial Interface (TWSI) bus.

Table 12. I2C bus descriptions













I ² C/TWSI Bus	Device	Part Number	Ref Des	Target Address (7-bit)	Location
TWO	External device connects to MIPI_DSI connector	Not applicable	J208	0xXX	SL16x0 I/O board
	External device connects to 40-pin Header	Not applicable	J32	0xXX	SL16x0 I/O board
	USB typr-C CC logic (reserved)	TUSB320IRWBR	U55	0x47 or 0x67	SL16x0 I/O-BOARD
	External device connects to LCD connector	Not applicable	J35	0xXX	SL1620 core module
	Current/voltage monitor for Vcore/1.8V/ 3.3V	INA3221	U9	0x40	SL1620 core module
	Current/Voltage monitor for 1.2V	INA220	U4	0x45	SL1620 core module
	IC GPIO Expander	FXL6408UMX	U1	0x44	SL1620 core module
	IC GPIO Expander	FXL6408UMX	U8	0x43	SL1620 core module
TW1	IC GPIO Expander	FXL6408UMX	U12	0x43	SL16x0 I/O board
	IC GPIO Expander	FXL6408UMX	U13	0x44	SL16x0 I/O board
	Current/voltage monitor for PWR_3V3	INA220	U76	0x40	SL16x0 I/O board
	Current/voltage monitor for PWR_1V8	INA220	U77	0x41	SL16x0 I/O board
	External device connects to 40-pin Header	Not applicable	J32	0xXX	SL16x0 I/O board
TW2	IC REG, default 0.8V Vout /5mV Step, 6A rating, Input 5.5V@Max, Step-Down Convertor with I2C	TPS628660AYCG	U39	0x49	SL1620 core module

Table 13. Short and voltage check points using any test point for ground

Ref Des	Form	Signal	Voltage
C123	Pad 2	PWR_LCD_BL	15V +/- 2% [14.7,15.3]
C414	Pad 1	PWR_5V	5.2V +/- 2% [5.096,5.304]
C6	Pad 1	PWR_3V3	3.3V +/- 1% [3.267,3.333]
Q3	Pad 2	PWR_1V8	1.8V +/- 2% [1.764,1.836]
C452	Pad 1	PWR_VDDM_1V2	1.2V +/- 2% [1.176,1.224]
C441	Pad 1	PWR_VDDM_2V5	2.5V +/- 2% [2.45,2.55]
R554	Pad 2	PWR_VCORE_FB	Vcore_FB +/- 2%

Downloaded by Anonymous () on 12 Jan 2026 18:22:27 UTC

5. Regulatory Compliance Certification

Region	EMC	RF	Safety	RoHS
CE(欧洲/Europe)		 		
FCC(美国/USA)	FCC logo is optional	CONTAINS FCC ID: RYK-WNFB265AXIBT (AP12275_M2P) ZQ6-AP6611S (AP12611_M2)		
IC(加拿大/Canada)	CAN ICES-003(B)/NMB-003(B)	CONTAINS IC: 6158A-NFB265AXIBT (AP12275_M2P) 11956A-AP6611S (AP12611_M2)		
UKCA(英国/United Kingdom)				
BSMI(台湾/Taiwan)	 D33088 RoHS	 CCXXxxYYyyZzW NCC ID will be ready after NCC cert in AMPAK.		
PSE(日本/Japan)		020-200125 (AP12275_M2P)  R 217-241405 (AP12611_M2)		
CCC(中国/China)		CMIIT ID will be ready after SRRC cert in AMPAK.		
BIS(印度)				
KCC(韩国)				

Downloaded by Anonymous () on 12-Jan-2026 18:12:27 UTC

6. References

The following documents are applicable to the SL1620 developer kit:

- *SL1620 Datasheet* (PN: 505-001428-01)
- *Astra Machina Foundation Series Quick Start Guide* (PN: 511-001404-01)
<https://github.com/synaptics-astra>

Downloaded by Anonymous () on 12-Jan-2026 18:12:27 UTC

7. Revision History

Last Modified	Revision	Description
April 3, 2024	A	Initial release.
May 8, 2024	B	Updated Figure 2 , Figure 3 , Figure 5 (line diagram, block diagram, I/O description of front view picture) and Features list.
June 14, 2024	C	Updated the following: <ul style="list-style-type: none"> • Section 0 • Features • Figure 7. LED locations on I/O board • Table 1. LED definitions on I/O board • Figure 9. Locations of jumpers on I/O board • Table 5. Hardware jumper settings definitions on I/O board • Table 7. I/O board connector definitions • Table 8. 260-pins SODIMM definition
September 16, 2024	D	Added section 5 Regulatory Compliance Certification .
January 6, 2025	E	Updated Features bullet related to 4-pin PoE+ connector.



Copyright

Copyright © 2024–2025 Synaptics Incorporated. All Rights Reserved.

Trademarks

Synaptics, SyNAP, Astra Machina, and the Synaptics logo are trademarks or registered trademarks of Synaptics Incorporated or its affiliates in the United States and/or other countries.

Arm and CoreSight are registered trademarks or trademarks of Arm Limited (or its subsidiaries) in the US and/or elsewhere. Bluetooth is a registered trademark of the Bluetooth Special Interest Group (SIG). Eardatek is a trademark of Eardatek Co., Ltd. Haier is a trademark of Haier Group. Infineon is a trademark of Infineon Technologies AG. Leadtek is a service mark of Leader Technologies, Inc. OmniVision is a trademark of OmniVision Technologies, Inc. PCI-e is a registered trademark of PCI-SIG. Samtec is a trademark of Samtec, Inc. TOSLINK are trademarks of Toshiba Electronic Devices & Storage Corporation. All other trademarks are the properties of their respective owners.

Contact Us

Visit our website at www.synaptics.com to locate the Synaptics office nearest you.

PN: 511-001407-01 Rev E

Notice

Use of the materials may require a license of intellectual property from a third party or from Synaptics. This document conveys no express or implied licenses to any intellectual property rights belonging to Synaptics or any other party. Synaptics may, from time to time and at its sole option, update the information contained in this document without notice.

INFORMATION CONTAINED IN THIS DOCUMENT IS PROVIDED "AS-IS," AND SYNAPTICS HEREBY DISCLAIMS ALL EXPRESS OR IMPLIED WARRANTIES, INCLUDING BUT NOT LIMITED TO ANY IMPLIED WARRANTIES OF MERCHANTABILITY AND FITNESS FOR A PARTICULAR PURPOSE, AND ANY WARRANTIES OF NON-INFRINGEMENT OF ANY INTELLECTUAL PROPERTY RIGHTS. IN NO EVENT SHALL SYNAPTICS BE LIABLE FOR ANY DIRECT, INDIRECT, INCIDENTAL, SPECIAL, PUNITIVE, OR CONSEQUENTIAL DAMAGES ARISING OUT OF OR IN CONNECTION WITH THE USE OF THE INFORMATION CONTAINED IN THIS DOCUMENT, HOWEVER CAUSED AND BASED ON ANY THEORY OF LIABILITY, WHETHER IN AN ACTION OF CONTRACT, NEGLIGENCE OR OTHER TORTIOUS ACTION, AND EVEN IF SYNAPTICS WAS ADVISED OF THE POSSIBILITY OF SUCH DAMAGE. IF A TRIBUNAL OF COMPETENT JURISDICTION DOES NOT PERMIT THE DISCLAIMER OF DIRECT DAMAGES OR ANY OTHER DAMAGES, SYNAPTICS' TOTAL CUMULATIVE LIABILITY TO ANY PARTY SHALL NOT EXCEED ONE HUNDRED U.S. DOLLARS.

Downloaded by Anonymous () on 12-Jan-2026 09:22:11 UTC